

[Home](#)

[Back to Shrinemaiden page](#)

Seam allowance 1/2in.

Bonding line Aa

Bonding line AA

Bonding line AA

Bonding line Ba

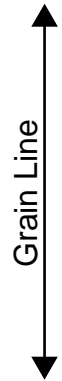

Bonding line AB

Bonding line AB

Bonding line Ca

Front body side

Bonding line AC

Fr

Bonding line AC

Bonding line Da

Shrine Maiden(Miko)
Body
two sheets



Bonding line AD

Bonding line AD

Sewing stop position

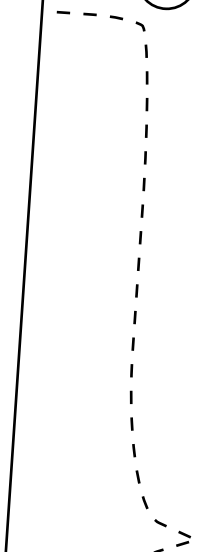

Fold and sew

Sleeve sewing stop

Bonding line AE

Bonding line Ea

Bonding line AE

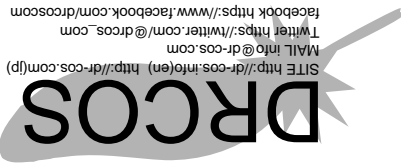

Bonding line Fa

Bonding line AF

Bonding line AF

Sleeve sewing stop

Fold and sew

Sewing stop position

Bonding line AG

Bonding line Ga

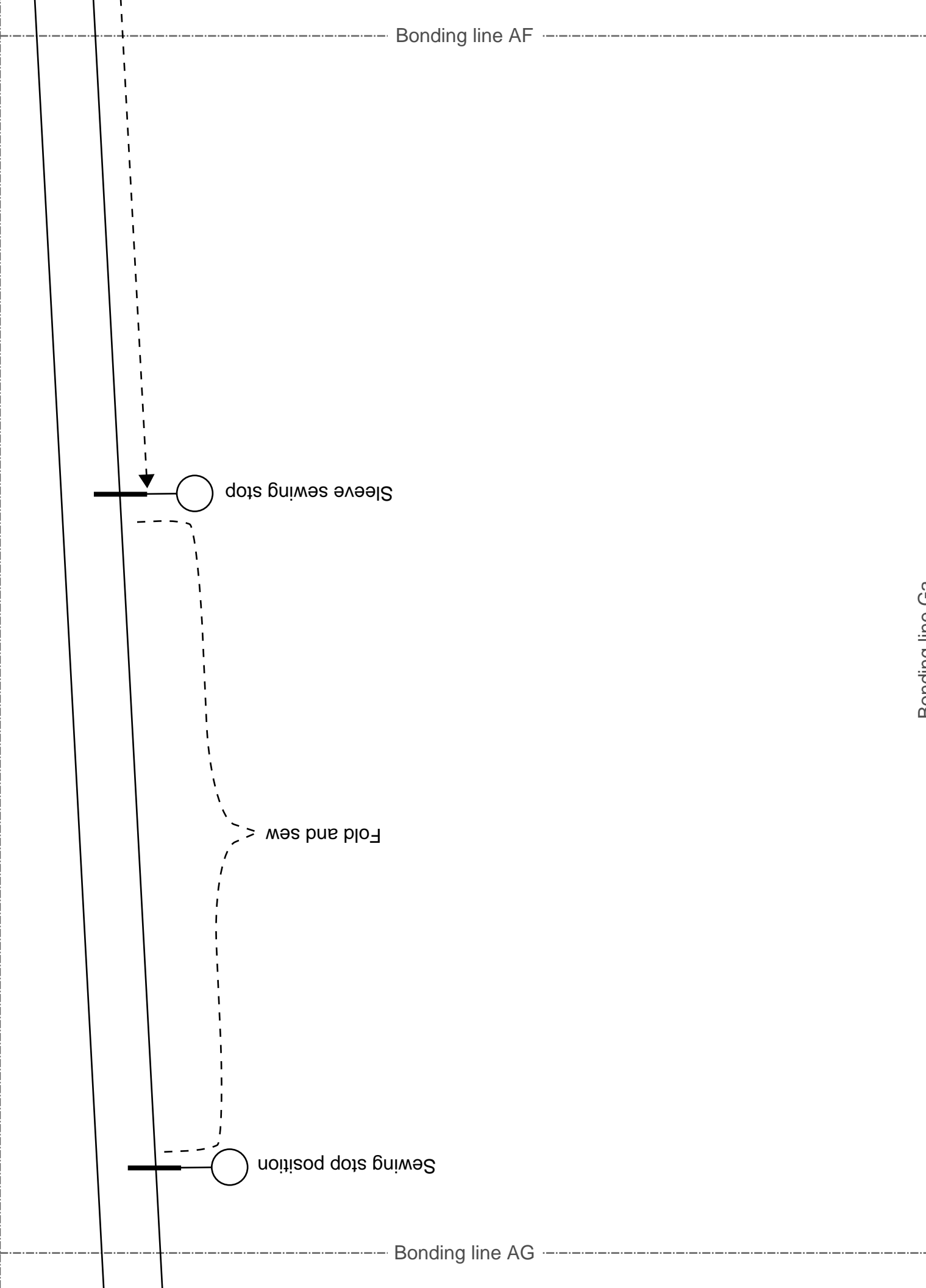

Bonding line AG

Back body side

Bonding line Ha

Bonding line AH

Bonding line AH

Bonding line Ia

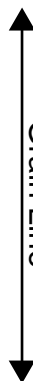

Grain Line

Bonding line AI

Bonding line AI

Bonding line Ja

Bonding line AJ

Bonding line AJ

Bonding line Ka

Seam allowance 1/2in

Bonding line Aa

Bonding line BA

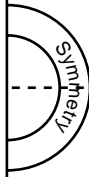

Bonding line Ab

Bonding line Ba

Bonding line BA

Bonding line Bb



Bonding line BB

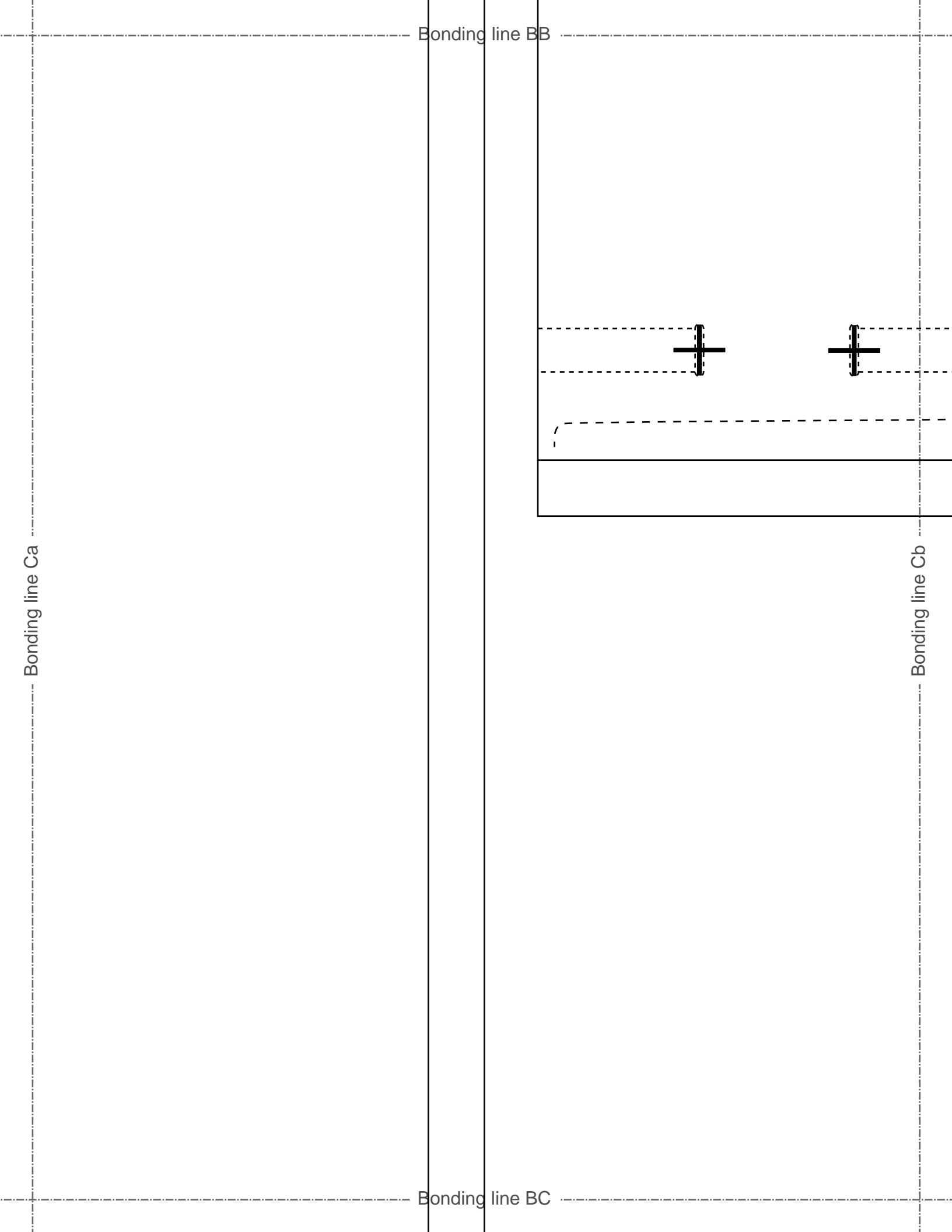

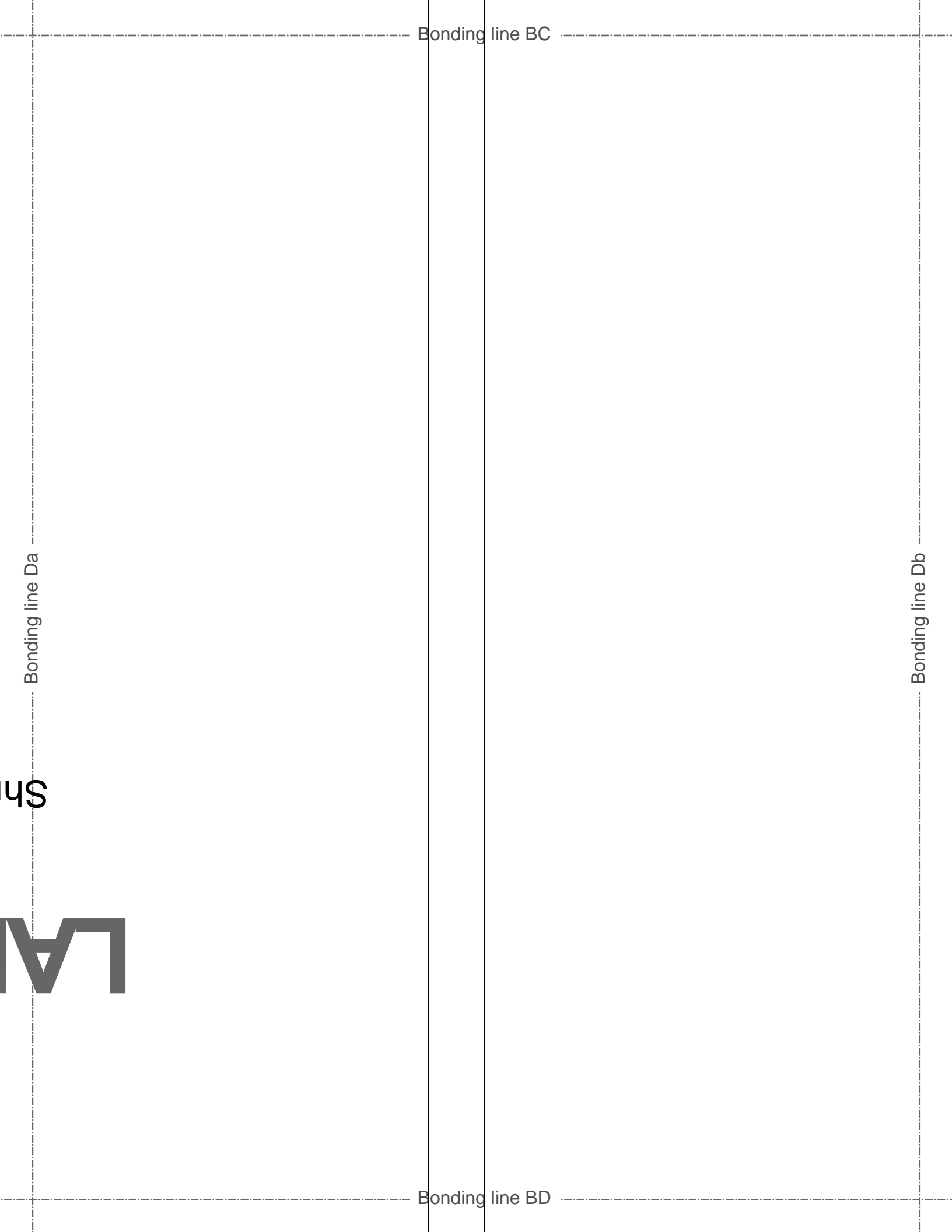

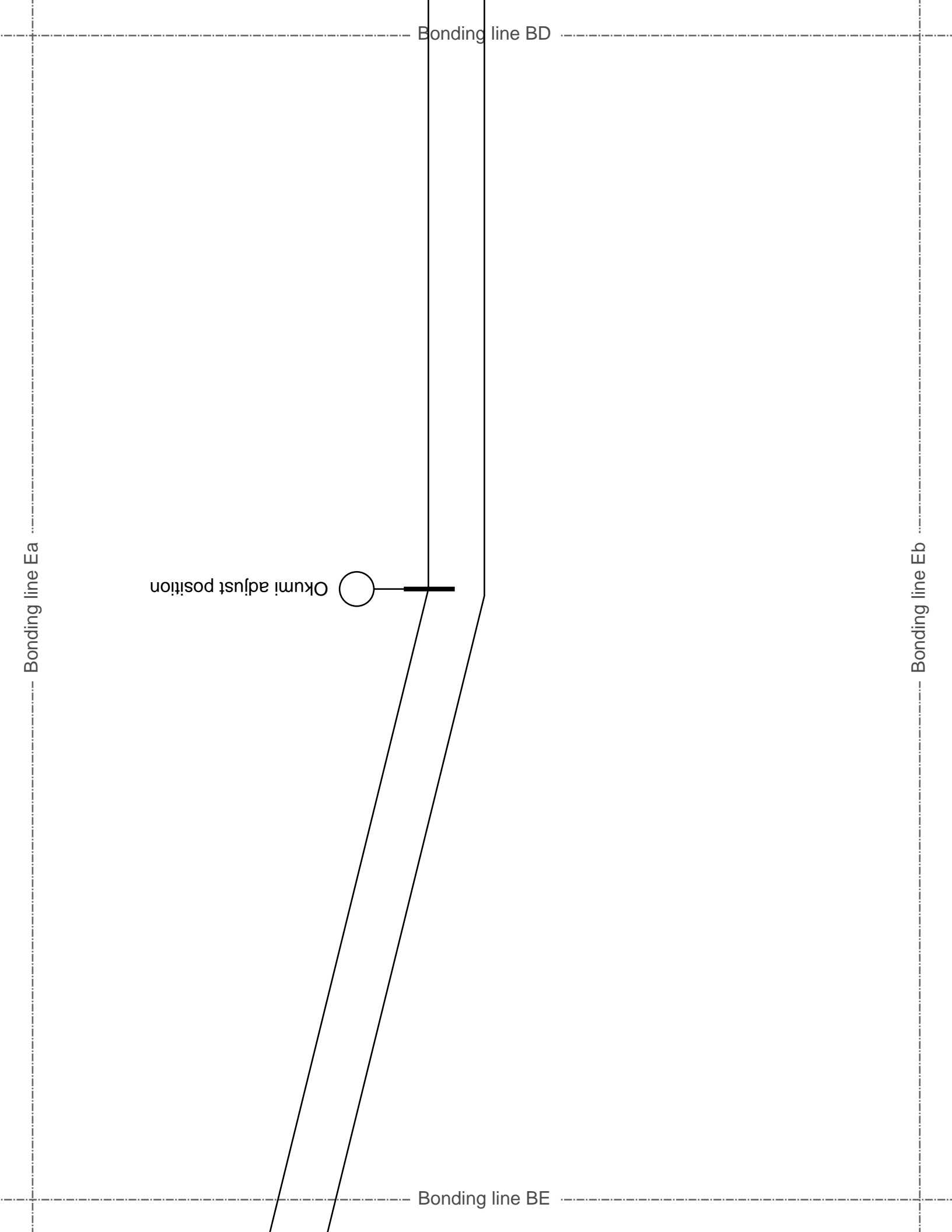

Bonding line BD

Bonding line Ea

Bonding line Eb

Okumi adjust position

Bonding line BE

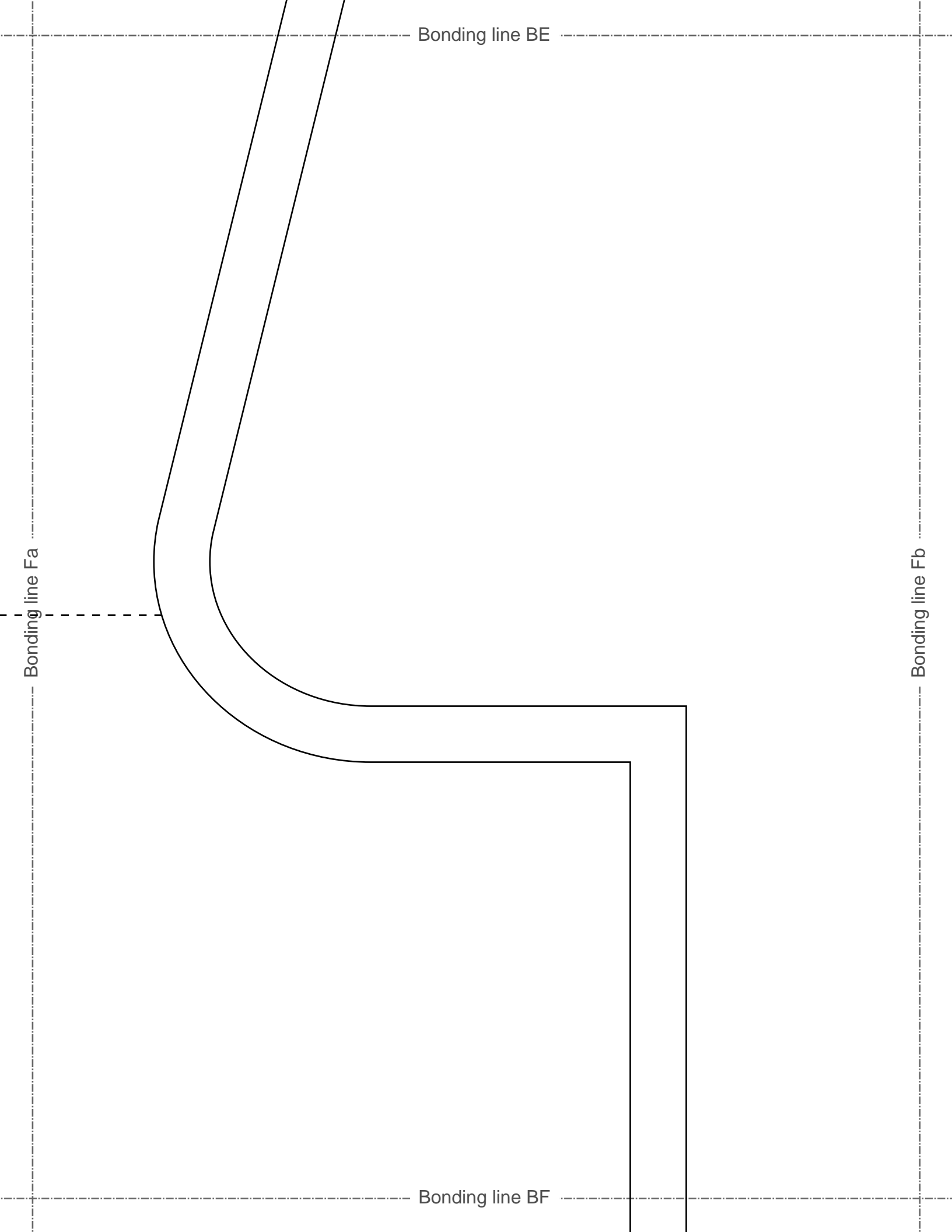

Bonding line BF

Bonding line Ga

Bonding line Gb

Bonding line BG

Bonding line BG

Bonding line Ha

Bonding line Hb

Bonding line BH

Bonding line BH

Bonding line Ia

Bonding line Ib

Bonding line BI

Bonding line BI

Bonding line Ja

Bonding line Jb

Bonding line BJ

Bonding line BJ

Bonding line Ka

Bonding line Kb

ce 1/2in.

Bonding line Ab

LADIES' ^{size} L

Shrine Maiden(Miko)

Inside collar

one sheets

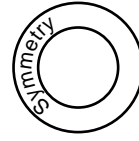

Bonding line Ac

Bonding line CA

LADIES'S size

Shrine Maiden(Miko)

sleeve

two sheets

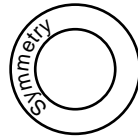

Sleeve sewing stop 



Bonding line CB

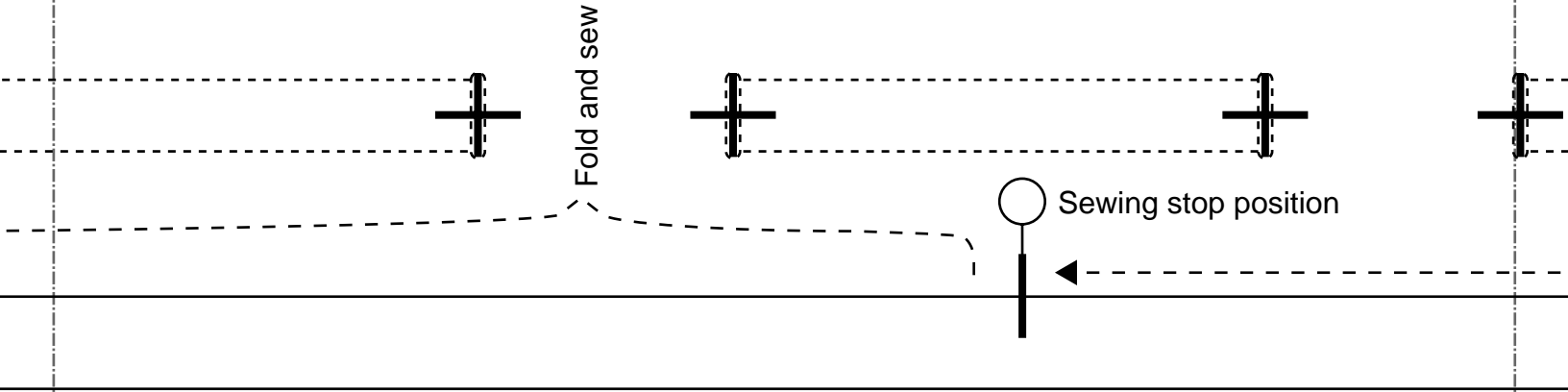

Bonding line Cb

Bonding line Cc

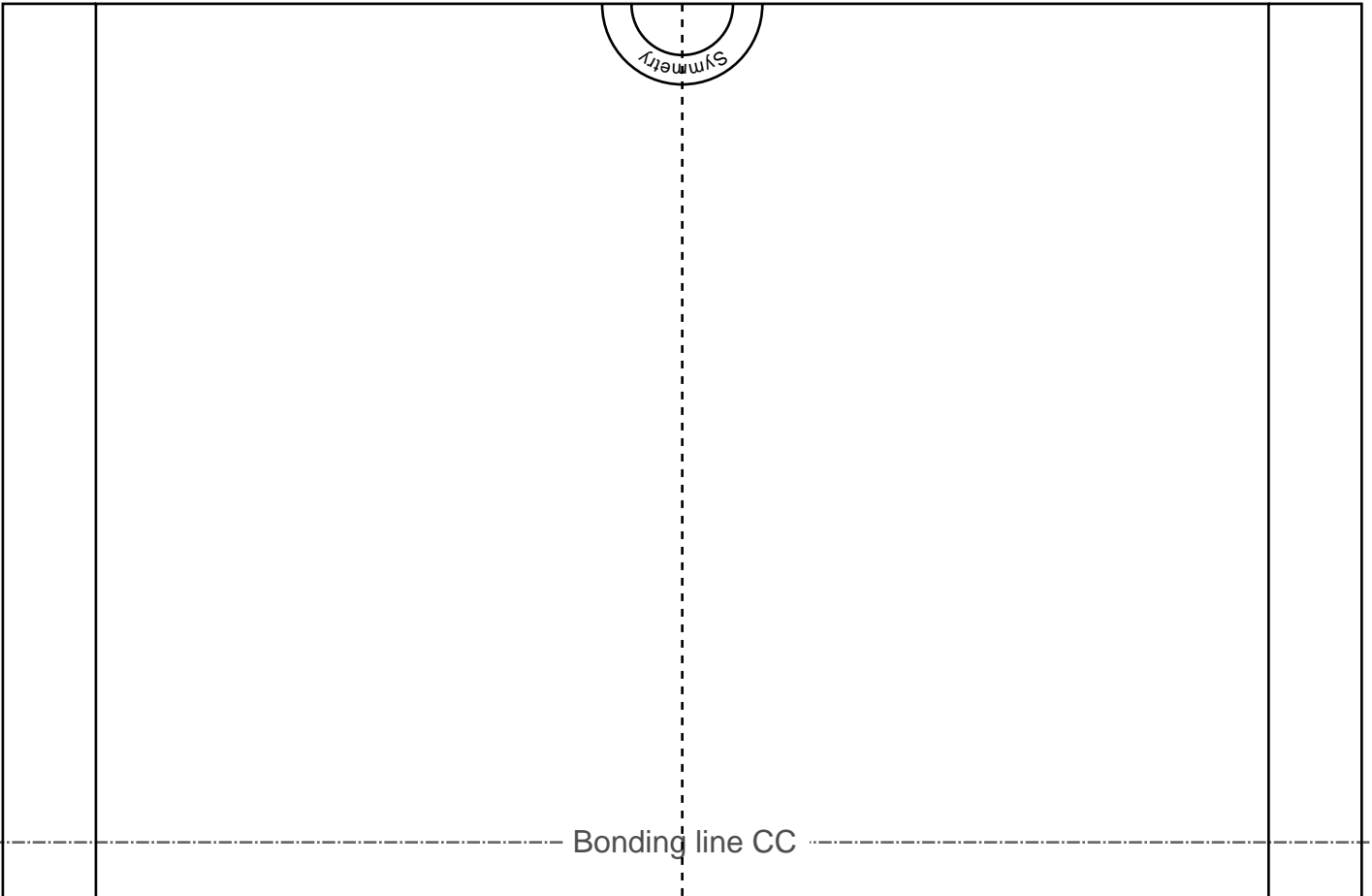

Bonding line CC

Bonding line CC

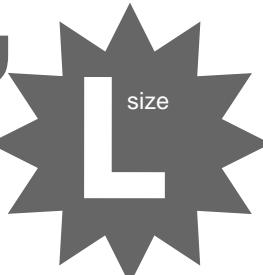
LADIES'  size

Shrine Maiden(Miko)

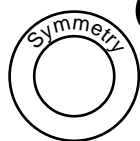

Outside collar
one sheets

Bonding line CD

Bonding line Db

Bonding line Dc

Bonding line Eb

Bonding line CD

Okumi adjust position

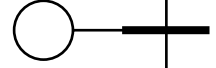

Bonding line Ec



Bonding line CE

Bonding line CE

Bonding line Fb

Bonding line Fc

DRCOS

SITE [http://dr-cos.info\(en\)](http://dr-cos.info(en)) [http://dr-cos.com\(jp\)](http://dr-cos.com(jp))

MAIL info@dr-cos.com

Twitter https://twitter.com/@drcos_com

facebook <https://www.facebook.com/drcoscom>

Seam allowance 1/2in.

Bonding line CF

Bonding line Ac

Bonding line Ad



Okumi adjust position

Bonding line DA

Bonding line DA

Fold and sew

Bonding line Bc

Bonding line Bd

Grain Line

Bonding line DB

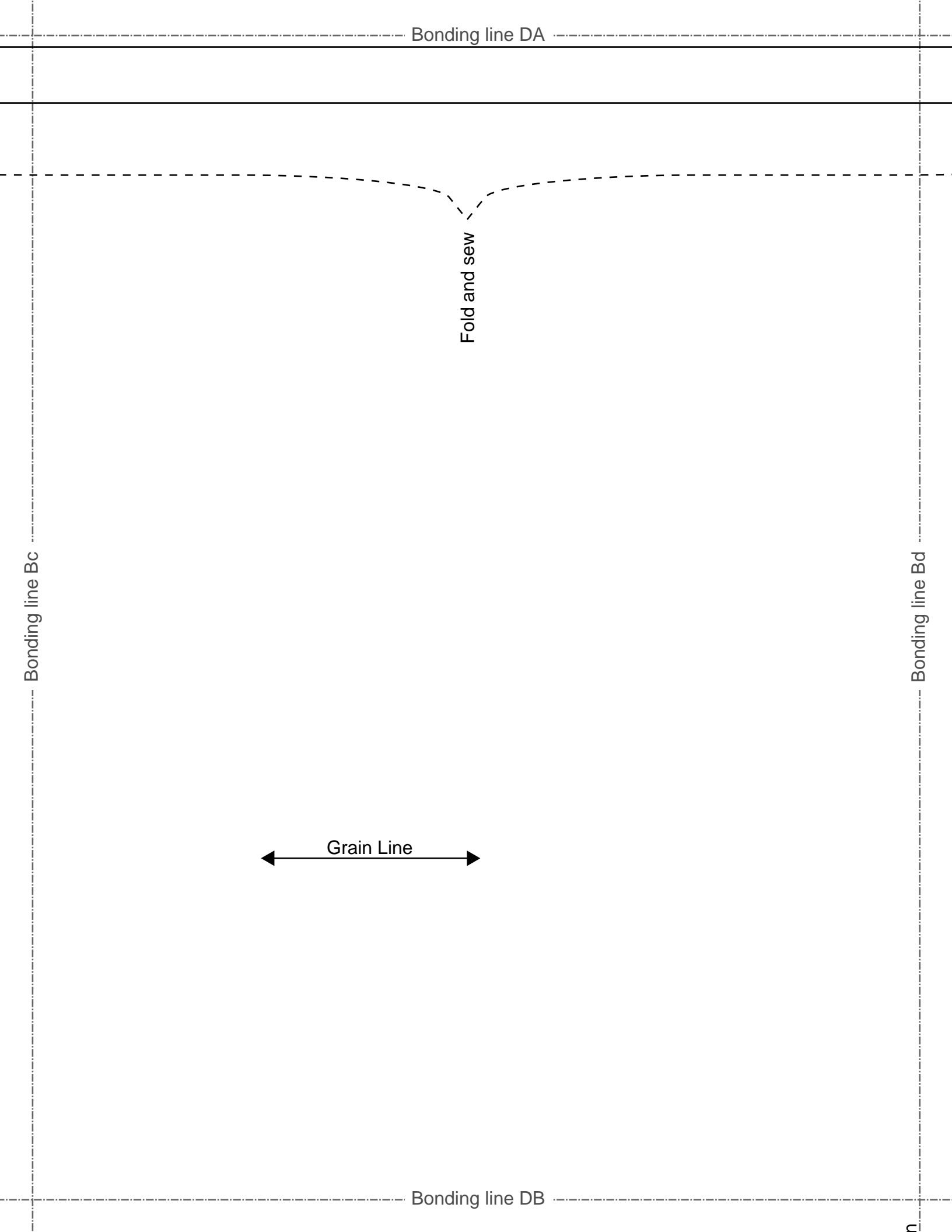

Bonding line DB

Button hole position



Bonding line Cc

Bonding line Cd

Bonding line DC

Bonding line Ad

Bonding line Ae

← Grain Line →

Bonding line EA

Bonding line Bd

Bonding line EA



Seam allowance 1/2in.

Bonding line EB

Bonding line Be

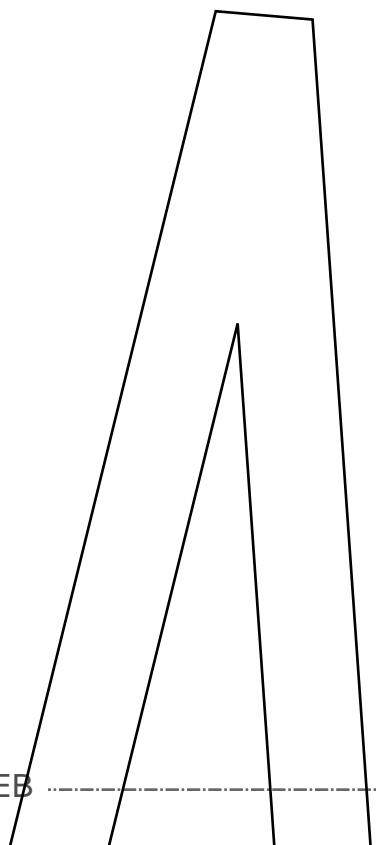

Bonding line EB

Button hole position

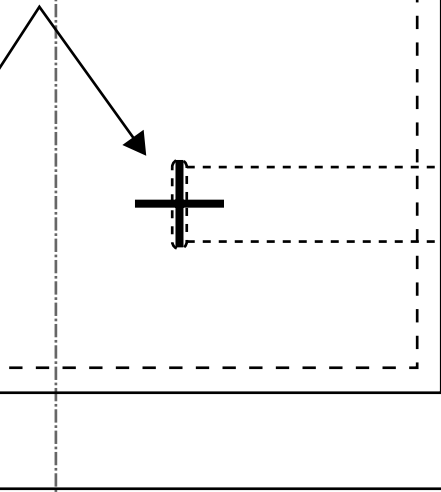

Bonding line Cd

Bonding line Ce

Bonding line EC

DRCOS
SITE <http://dr-cos.info/en> <http://dr-cos.com/jp>
MAIL info@dr-cos.com
Twitter https://twitter.com/@drcos_com
facebook <https://www.facebook.com/drcoscom>

Bonding line EC

Bonding line Dd

Bonding line De

Collar adjust position

Baste

Bonding line ED

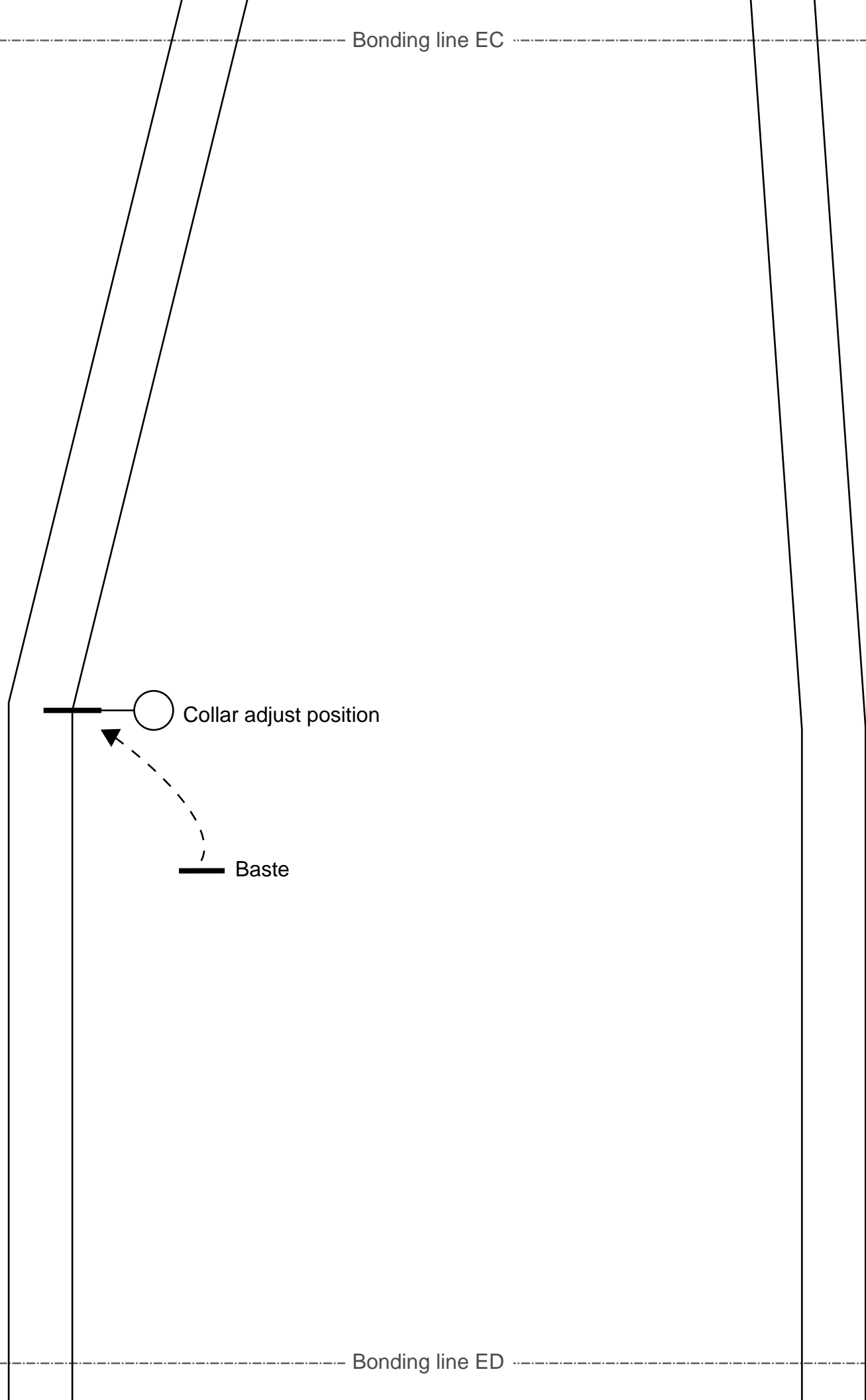

LADIES'  size

Shrine Maiden(Miko)
Okumi
two sheets

Bonding line EE

Bonding line Fd

Bonding line Fe

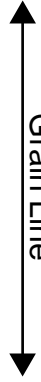

Seam allowance 1/2in.

Bonding line EF

Bonding line Ae



Seam allowance 1/2in.

Bonding line Af

Bonding line FA